

Prospects for Migration of Hybrid Fiber/Coax technology to a Fiber to the Home Implementation

Ken Pyle

Raynet Corporation
155 Constitution Drive
Menlo Park, CA 94025

Introduction:

In the past 18 months, Hybrid Fiber/Coax (HFC) technology has gained wide spread acceptance as the preferred platform for telco implementation of video services in the local loop, as it provides the most cost effective way to deliver today's existing analog services while providing compatibility with tomorrow's switched digital services. The case for HFC is bolstered by its ubiquitous use by the CATV industry for distribution of programming in the "last mile".

In this paper, Hybrid Fiber/Coax (HFC) is defined as an RF transport system which uses a combination of optical and coaxial technologies for interconnecting a headend or hub to residential subscribers. The modems required to provide ATM interconnection of switched video service, local area network extension, or telephony service lie beyond this definition of HFC. Current HFC architecture serving area sizes are typically between 250 to 500 homes, as these provide the optimum cost/performance trade-off. As these node sizes decrease, the effective bandwidth and service capability of the HFC approach increases accordingly.

HFC is cost-effective because the service areas sizes allow significant sharing of the electro-optic components. As the cost of the electro-optics drops, even smaller node sizes and greater effective bandwidths will be supported. Since HFC is compatible with the embedded base of approximately 280 million analog CPE and, soon to be released, digital RF CPE, migration towards smaller node sizes, such as Fiber to the Home (FTTH), favors the HFC approach over alternative technologies. This paper concentrates on the migration of today's HFC technology to an RF based, Fiber to the Home implementation.

Methodology:

Fiber to the Home will be implemented when it results in either a reduction of local loop life cycle costs or it allows unique services to be offered that will generate increased revenue. A model, based on current CATV architectures and representing the typical HFC system, will be provided to serve as a reference for network life cycle costs and service capabilities. Projected roll-out dates and expected network capacity requirements for future services will also be provided. Technical challenges regarding key elements of HFC will be examined. Exogenous factors, such as competition and performance improvements, will be reviewed. Finally, projected roll-out dates will be provided.

Baseline Model

Today's existing CATV networks provide the departure point for discussing the evolution of hybrid fiber/coax RF transport to an FTTH implementation. These systems, which have evolved over the past 40 years now pass 96% of U.S. households with 55 million of those households subscribing.

The use of fiber optic technology in CATV networks began in the late 1970s and was primarily used for supertrunking signals from signal origination sources to distribution locations, such as headends or hubs. These supertrunking systems required signal format conversion from AM carriers to either FM carriers or baseband digital signals to compensate for the non-linear characteristics of the laser transmitters. In the late 1980s, highly linear laser transmitters were introduced, eliminating the need for format conversion of the AM carriers. The resulting per channel cost reduction was the catalyst for the introduction of fiber into the CATV distribution network.

This highly linear fiber transport technology allowed a reduction in the number of trunk amplifiers, improving system reliability, performance and expanding service possibilities. The evolution of this technology into a HFC implementation is depicted in figure 1. For the purposes of this paper, this architecture is characterized as HFC because of the relatively deep penetration of fiber in the network and the small node sizes. These characteristics allow the introduction of interactive services such as telecommuting, video on demand, and telephony.

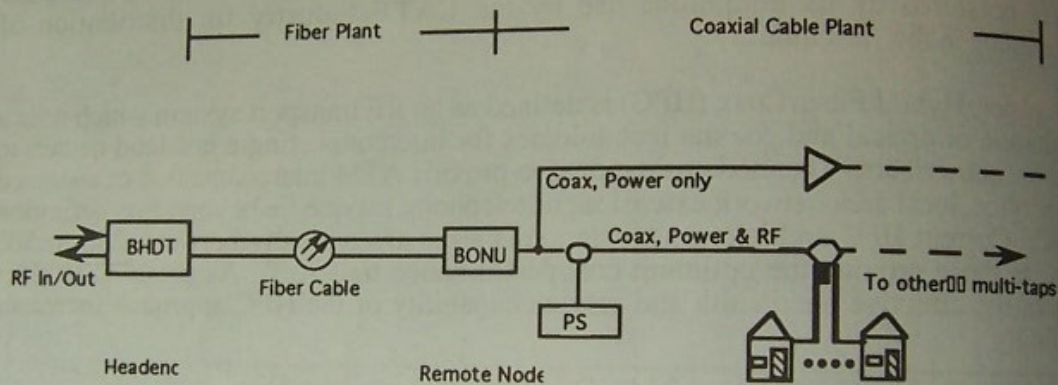

Figure 1, Typical Active Fiber/Coax network architecture

The typical serving area for HFC is dependent on home density and varies from 250 to 500 homes per BHDT (Broadband Host Distribution Terminal) serving area. The BHDT provides conversion between RF and optical transmit/receive signals. The downstream bandwidth is generally 54 to 750 MHz with a return band of 5 to 42 MHz. The amplifier cascade between the BONU (Broadband Optical Network Unit) and the last passing is typically restricted to three or fewer. This limited cascade improves the perceived reliability of the network and facilitates the use of the 5 to 42 MHz return band for interactive signaling.

HFC architectures are being designed for a migration to a passive coaxial architecture. This migration, shown in figure 2, replaces amplifiers with BONUs which have equivalent RF output levels. For upgrades to existing systems, the implication is that spare fibers must be available and in proximity to the amplifiers. Since spare fibers are installed initially, the costs associated with upgrading to a passive HFC architecture are primarily the incremental additions of BHDT and BONU electronics and their installation, while the incremental construction cost is minimal. In this scenario, the coax cable which was previously utilized for signal and power transport, would be used to power the BONUs.

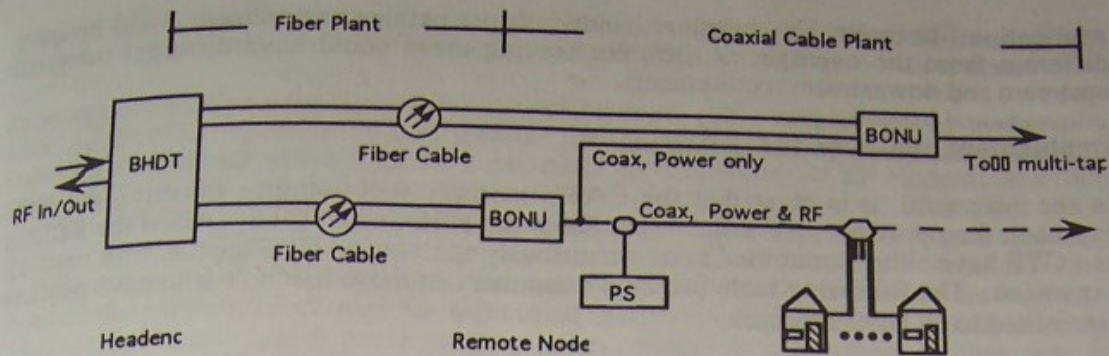

Figure 2, Migration to Passive Fiber/Coax network architecture

The CATV industry has traditionally expanded their network capabilities on a cost-parity basis with their existing architectural approach. In other words, new architectures, which provide either enhanced bandwidth or smaller node sizes, are deployed when they are at roughly equivalent per passing costs of existing architectures. Table 1 shows the relatively low cost of HFC bandwidth and its rapid decline as a function of time. Additionally, if the trend to smaller node sizes extends linearly over time, then a FTTH architecture would be economically feasible in the 2007 to 2010 time period.

Downstream Homes/Node	10,000 homes passed per node	2,000 homes passed per node	500 homes per node	500 homes per node
Downstream BW	54 to 550 MHz	54 to 750 MHz	54 to 750 MHz	54 to 860 MHz
Downstream BW/Passing	50 kHz/Psg	350 kHz/Psg	1.39 MHz/Psg	1.61 MHz/Psg
Upstream Homes/Node	10,000 homes passed per node	2,000 homes passed per node	500 homes per node	100 homes per node
Upstream BW	5 to 30 MHz	5 to 30 MHz	5 to 42 MHz	5 to 42 MHz
Upstream BW/Psg	2.5 kHz/Psg	12.5 kHz/Psg	74 kHz/Psg	370 kHz/Psg
Cost/kHz/Psg	\$4.80	\$.70	\$.17	\$.13
	1988	1991	1994	1995 est.

Table 1, Cost/kHz/Psg over Time

The bandwidth in the above table is normalized to a kHz per passing. The costs assume \$250 per passing for the distribution portion of the network, exclusive of drop wiring.¹ This number is representative and could be higher or lower depending on specific

¹ Residential Fiber Optic Networks, pg 119, David P. Reed, 1992, Artech House, Norwood, MA, 02062

application. In reality the marginal bandwidth per passing requirement could be quite different from the average, as different serving areas could have different marginal upstream and downstream requirements.

Deployment plans of the RBOCs:

In the near term, it is clear that the CATV industry will continue pursuing the HFC approach for network expansion. What about the RBOCs and GTE? All of the RBOCs and GTE have either committed to or are seriously studying an HFC approach for network expansion. The following table presents a summary of those RBOC's who have publicly committed to an HFC approach.²

RBOC	Passings @ year 2,000	Platform
Ameritech	6 million	HFC, 750 MHz
NYNEX ³	.5 million by 1997	HFC, 750 MHz
Pacific Bell	5 million	HFC, 750 MHz
US West	2.5 million	HFC, 750 MHz

The important thing to note about this table is that each of these RBOCs will have a significant portion of their embedded base served by HFC in the year 2000. Upgrades to this embedded base will certainly be via network extensions using the migration path described in figures 1 and 2. Upgrades to their initially installed networks would not be expected to occur until at least after a depreciation period of 7 to 10 years. The end of this depreciation period would be the earliest that these RBOCs' initial installations would be upgraded to FTTH.

Services:

The services that potentially have to be transported over an HFC network vary from today's broadcast analog video to tomorrow's interactive digital video on demand. Because HFC is an RF based transport system, multiple modulation formats, such as AM video, FM audio, and digital signals, coexist in the same medium. The broadband bandwidth of the HFC approach allows compatibility with today's existing Consumer Premise Equipment, such as televisions, video cassette recorders and stereos. Direct compatibility with CPE is significant, as over 30 million of these devices are sold annually in the U.S. market.⁴ Because of the lack of embedded conditional access within the existing CPE, broadcast services are the only type of services currently supported by existing CPE.

Through the use of external RF modems or set-top converters, HFC is also compatible with services beyond the narrow universe of the existing CPE. For the purposes of this paper, these devices are defined as providing compatibility between a service's unique signal format and the existing base of CPE. An example of this modem functionality, as applied to the HFC architecture, is the set-top converter. Specifically, the set-top converter selectively translates a scrambled signal into its original format and sends this descrambled signal to CPE, such as television or VCR. RF Modems and set-top converters facilitate the introduction of new services by allowing the use of existing CPE and only needs to be

² "Telcos rush headlong into video", pg.30, R. Brown, L. Ellis, Apr. 1994, CED, Chilton Pub., NY, NY
³ "NYNEX broadband train pulls into Massachusetts", D. O'Shea, 4/18/94, Vol. 226 No. 16, Overland KS
⁴ Television & Cable Factbook, pp. 1-6, 11, Volume no. 62, 1994, Warren Publishing, Washington D.C. 20037

added to those subscribers desiring the new service. In general, the functionality of a modem or set-top migrates to the CPE when a specific service reaches a critical mass.

Existing services and those services which are expected to be commercially introduced in the next few years are presented in table 2. This table is categorized by those services which are directly compatible with CPE and those services requiring RF modems or set-top converters. In this table, the set-top converters provide conditional access for video signals and are the interface between the HFC network and the video CPE (e.g. televisions, VCRs). The RF modems convert digitally modulated RF signals to a baseband format suitable for subscribers' computers. The telephony RF modems provide an interface between the HFC network and the individual telephony subscribers. Versions of the telephony modems which allow sharing among multiple subscribers or that may be installed on a per subscriber basis will be available.

	Service Type	Today's Services	New Services expected in the 1995-1997 time frame
Services compatible with existing CPE		Broadcast AM FM Audio Advertising	HDTV
Set-tops	Broadcast Services	Premium	Digital NVOD
	Interactive Services	Advertising PPV	Video on Demand Education Games Shopping/Transactional
RF Modems	Broadcast Services	Digital Audio Data delivery	
	Interactive Services		Education Games Shopping/Transactional Telecommuting
Telephony Modem	Interactive Services		Telephony

Table 2, Services expected to be transported via an HFC system

Having determined the basic set of services, the next step is to attempt to understand the per passing bandwidth requirements of these new services. Assuming that a subset of the services listed above are introduced in the next few years, when will these services have significant deployment? Table 3 summarizes the estimated year 2000 upstream and downstream bandwidth requirements of the services outlined in Table 2.

	Telephony Modem	RF Modem	Set-top
Upstream Bw/psg	50-150 kHz/psg	12 kHz/passing	<2 kHz/psg
Downstream Bw/psg	50-150 kHz/psg	12 kHz/passing	≈1.2 MHz/psg

Table 3, Year 2000 estimated service requirements normalized to bandwidth per passing

It is expected that it will be five to ten years after standards finalization for HDTV to even reach one percent penetration.⁵ Therefore, because of its insignificance in the near term, it is not included in the above table. Additionally, the meaning of HDTV is becoming blurred as broadcasters are planning on using this bandwidth for digital transmission and not necessarily for transmission of High Definition Television.⁶

The estimate for telephony services assumes 1.2 telephony lines per passing and that telephony service could be made available to 100% of the passings. The bandwidth range is indicative of the fact that a variety of RF modulation schemes are currently available for telephony modems.

The bandwidth requirement for the RF modems assume that their growth rate is similar to that of high speed telephony modems. In fact, from a user's standpoint, they are an extension of today's high speed telephony modems. Assuming that the RF and telephony modems have a similar growth rate, then, within four years approximately 10% of modem sales would be due to the high speed modems.⁷ At the most, this would imply an average of 50 users per 500 passings. This could easily be handled by an RF ethernet modem utilizing one 6 MHz upstream and one 6 MHz downstream channel.⁸

Regarding the set-top requirements, current set-top designs typically use a shared frequency for transmitting signaling information for PPV and interactive services. For real-time transactional services, such as Video on Demand, set-tops are being developed which require less than one MHz of upstream bandwidth (less than one MHz for 500 passings). Assuming the above telephony and RF modem spectrum requirements, the remaining bandwidth could be used to deliver various bandwidth portfolios. For example, the bandwidth could be configured as follows:

- 77 AM channels plus FM audio occupying 482 MHz
- 20 ea, 3.3 MB/s, MPEG NVOD movies @ 15 minute intervals
- Video on Demand with 14.4 % channel availability @ 100% penetration.

Note, the above portfolio assumes 16-VSB modulation which provides for 12 ea, 3.3 MB/s MPEG compressed channels per RF carrier.

⁵ "Scenarios for compressed Video in Cable Practice", W. Ciciora, pp. 123-127, 1991 NCTA Technical Papers, NCTA, Washington D.C., 20036

⁶ HDTV Report, pp 5,6, Vol. 4 No. 4, Feb. 16, 1994, Phillips Busine Information, Washington D.C., 1993, p. 9, CMP Publications, Inc.

⁷ "U.S Modem Revenue Share Forecast Through the Retail Channel", Computer Retail Week, Jan. 18th, 1993, p. 9, CMP Publications, Inc.

⁸ "Ethernet extensions via a Bandwidth Transport application overlay in FITL", R. Murphy, B. Brotherton, K. Pyle, pp. 239-253, NFOEC, Book 2, June 1993, Southwestern Bell/Bellcore

The above capacity is more than ample to cover most projections for video services in the next few years. For instance, despite the large number of cable networks in the last decade, the four broadcast networks (or the equivalent of 24 MHz) still garner 46% of all viewing shares in CATV systems.⁹ The point is that, in the next few years, service requirements will not require the network to be FTTH.

Technology Challenges:

The eventual migration to a fiber to the home architecture which uses the hybrid fiber/coax system as its basis, is depicted in the generic block diagram of figure 3. This figure assumes that the BONU is replaced with an optical node, which at the most basic level, would provide fiber management capability. To minimize construction cost and to facilitate fiber management, it is assumed that feeder fiber to this point is adequate. A dedicated fiber from the optical node to the home is assumed, as this has been found to be the lowest cost interconnect method.¹⁰

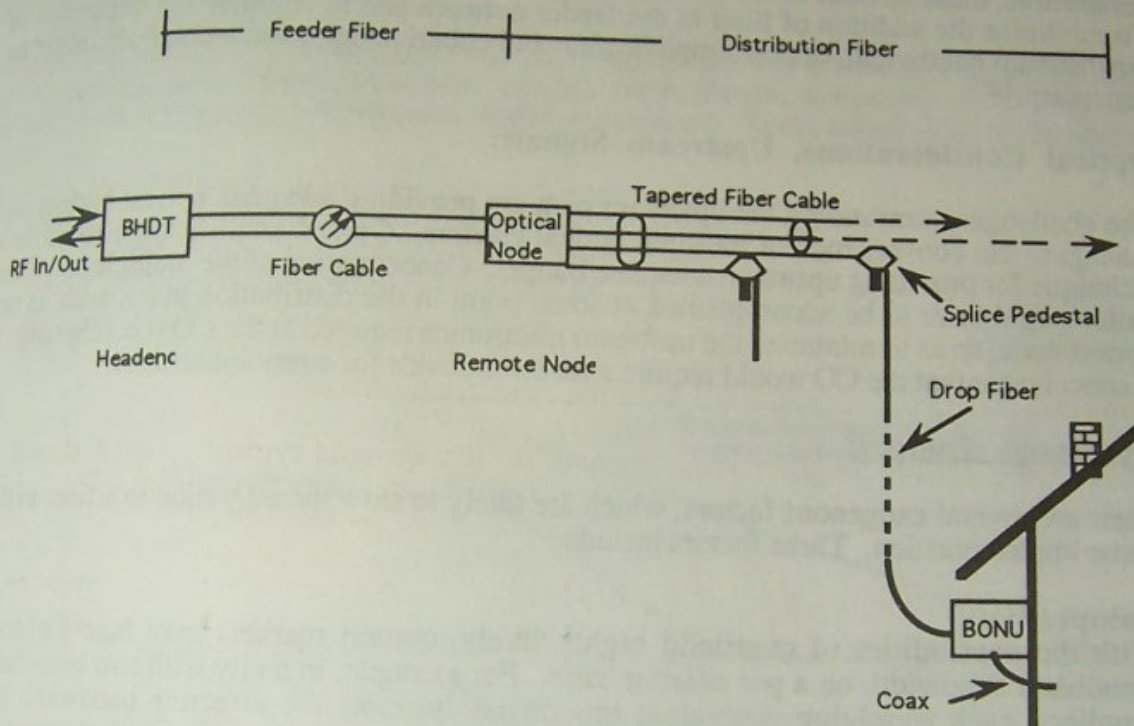

Figure 3, HFC Migration to FTTH

The technical considerations in implementing an HFC FTTH system include lifeline powering of the BONU and the optical performance requirements for both downstream and upstream signals. An in-depth analysis of these issues is beyond the scope of this paper, however some of the issues surrounding each of these areas are as follows:

⁹ Cable Television Developments, pg. 5-A, May 1992, Vol. 16, No. 58, NCTA, Washington D.C., 20036

¹⁰ "Prospects for Cable Fiber to the Home", pg. 519, Nick Hamilton-Piercy, Robb Balsdon, Symposium Record, Cable TV Sessions, 17th International Television Symposium and Technical Exhibition, Montreux, Switzerland, June 13-18, 1991

Lifeline Power:

A requirement to provide lifeline powering of telephony services, should be a non-issue for a fiber to the home solution, as a similar issue will have to be resolved for HFC systems which support RF telephony modems that are at the side of the house. The key issue is who provides the power? If power must be provided by the network provider, the implication is that a coax drop feeds power from a common network. Advances in battery and solar technology may someday provide an alternative method for the network operator to provide lifeline power for telephony services.¹¹

Optical Considerations, Downstream Signals:

Devices must be developed which provided adequate optical budget to compensate for the extra optical splitters implicit in an all passive fiber network. From a downstream perspective, these devices could be an evolution of existing DFB and external modulators. To minimize the addition of fiber in the feeder network and to continue the expansion of downstream bandwidth, optical amplification and coherent detection techniques might be necessary.¹²

Optical Considerations, Upstream Signals:

The challenges surrounding the upstream path are providing adequate optical budget and managing the convergence of multiple optical carriers. Optical amplification could be a technique for providing upstream adequate budget. Concentration of the multiple upstream paths would have to be accomplished at some point in the distribution plant, such as the optical node, so as to minimize the upstream electronics required at the CO (i.e. otherwise it is conceivable that the CO would require a receiver device for every subscriber).

Exogenous Factors:

There are several exogenous factors, which are likely to slow the migration to a fiber to the home implementation. These factors include:

Competition:

With the possibilities of overbuild highly likely, certain markets may face a glut of broadband bandwidth on a per passing basis. For example, in a city with two broadband suppliers, each supplying equivalent broadband systems, the effective bandwidth per passing would be twice as much as shown in table 2. Competition from wireless operators (MMDS and DBS) also will provide additional choices for consumers and could add to a bandwidth oversupply. This oversupply of bandwidth could double the length of time it will take for FTTH to become cost-effective.

Performance Improvements:

The continuing improvement in modem and compression technology will continue to allow more information to be transported over a given bandwidth. This performance increase may be somewhat offset by the increasing bandwidth demands from higher resolution programming and future bandwidth intensive interactive services. Increased substitution of digital RF carriers for analog carriers will increase the efficiency of the HFC payload. For instance, converting 30 analog carriers to digital carriers translates into at least six times as

¹¹ "FITL Solar Power ONUs", pp 193-197, John Matthes, NFOEC, Book 3, June 1993, Southwestern Bell/Bellcore

¹² Coherent Systems for Cable TV: Opportunities and Obstacles", J. Glaab and D. Huber, pp 87-97, Fiber Optics Plus 1992 Proceedings Manual, SCTE, Exton, PA, 19341

much payload. Additionally, performance improvements in optical and RF components allow greater bandwidths to be supported. As the system migrates to smaller node sizes, greater coaxial cable bandwidths become easier to support.

Alternate Technologies:

Another factor which could slow the need for fiber to the home is the development of alternate technologies. Two such alternate technologies are wireless and baseband digital fiber transport (e.g. SONET transport). From a users point of view, wireless transmission potentially offers increased utility as it may provide complete freedom of movement, while eliminating the need to place electronic appliances near coax connections. From a network perspective, the elimination of the drop wire or fiber eliminates up to 20% of the total network cost.¹³ Another technology which could delay or obviate the need for an HFC FTTH solution is baseband digital transport as this may offer earlier solutions to the technical challenges of FTTH.

FTTH Implementation Dates:

The HFC architecture will migrate to an FTTH approach when it reaches cost parity with other network interconnect methods. As has been shown, a number of factors will influence the commercial introduction of this architecture. These influences are illustrated in figure 4.

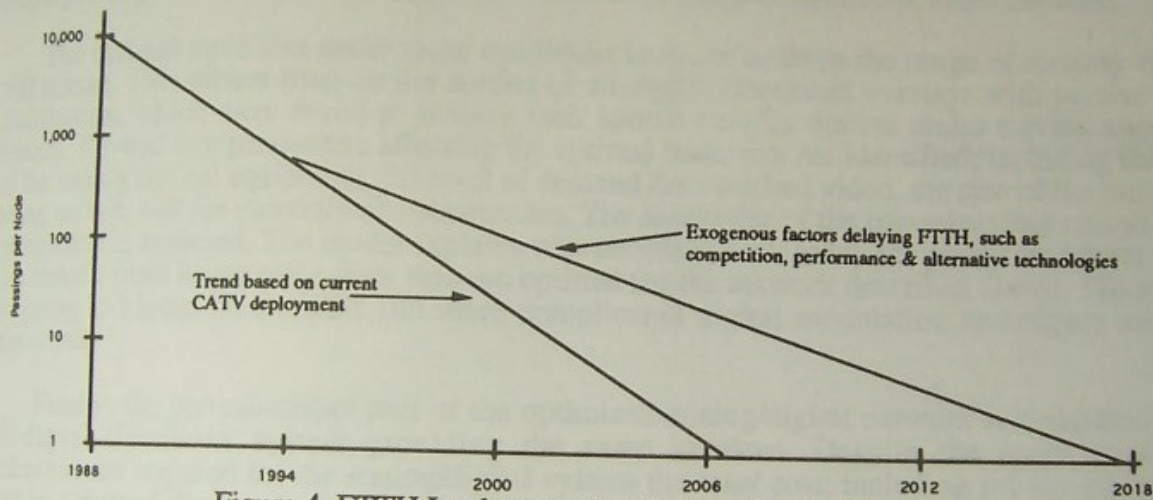

Figure 4, FTTH Implementation Roll out Projection

The above projection for commercial viability of this technology corresponds to others' predictions.¹⁴ In summary, initial commercial realization of an HFC FTTH implementation is most likely to occur sometime between 2007 and 2018.

Conclusion:

A model, based on current CATV architectures and representing the typical HFC system, has been provided as a reference for network installed first costs and service capabilities. Projected roll-out dates and expected network capacity requirements for future services have been given. The technical challenges in migrating HFC to an FTTH architecture have been .

¹³ Residential Fiber Optic Networks, pg 120, David P. Reed, 1992, Artech House, Norwood, MA, 02062

¹⁴ "New engineering title: Technology futurist?", pp. 20-22, K. Rauch, D. Wolfe, CED, Apr. 1994

discussed. Exogenous factors, such as competition and performance improvements, have been examined.

Based on current CATV deployment trends, RBOC deployment plans and exogenous factors, the earliest migration of the HFC architecture to an FTTH implementation will be in the 2007 to 2018 time frame. Several technological issues will have to be resolved before FTTH can be commercially viable. In the meantime, the HFC architecture deployed today will profitably support current services, while providing the basis for migration to a FTTH architecture serving tomorrow's enhanced service requirements.

Acknowledgements:

The author wishes to thank his colleagues at Raynet for their help in reviewing and refining this paper.

T
video
Fiber
provi
digit
servi
assu
emp

300
dist
hor
of t
bei
par
car
of
dis

al
in
ca
de

1

v
a
s
i
y
i